

Direct-Drive Technology

Introduction

 **ONE MOTION**



What is Mag-Drive Technology?

Mag-Drive is a brushless DC permanent magnet motor with an outrunner design.

This technology consists of a stator with coils and a rotor with permanent magnets attached to a ring or sleeve on the outside of the stator coils.

As a result, the device has a rotating ring or sleeve, instead of a rotating shaft.

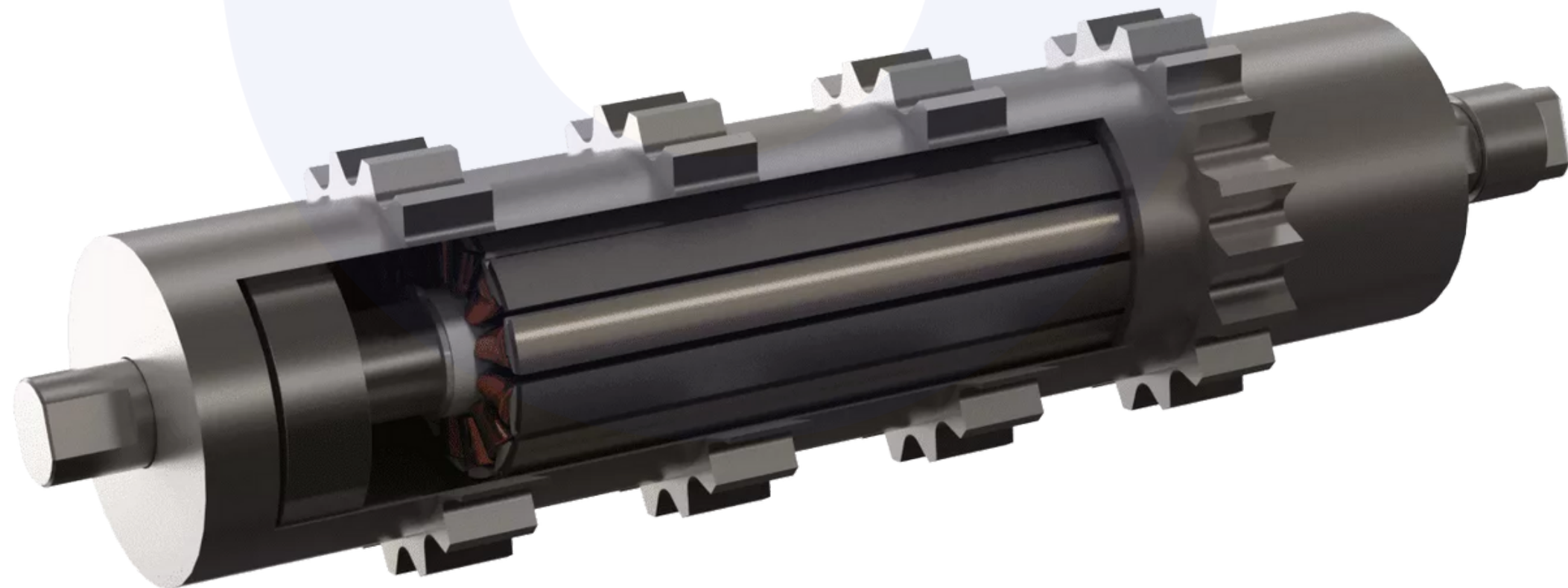

One Motion Core
Internal Stator w/ Coils

Outrunner Design

On an outrunner motor, the rotor is located on the outside of the stator.

Outrunner motors produce more torque for the same build volume compared to inrunner motors.

Electromagnetic field lines pass from rotor to stator over a larger surface area.

- More electromechanical force is generated leading to higher torque levels. (Especially at low speed.)
- Direct transfer of electrical power to mechanical rotation.
- No wasted energy moving through mechanical gears.

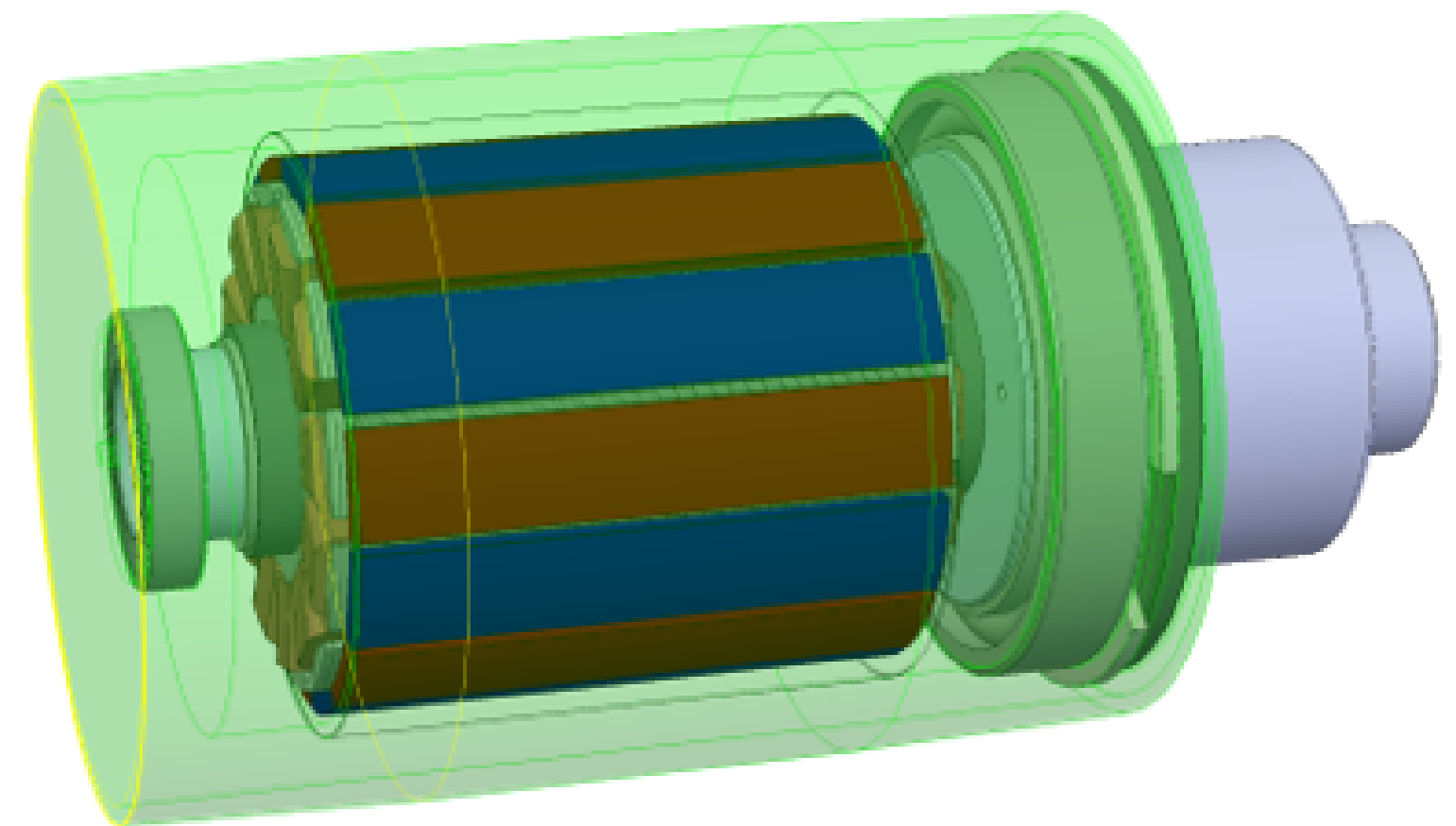
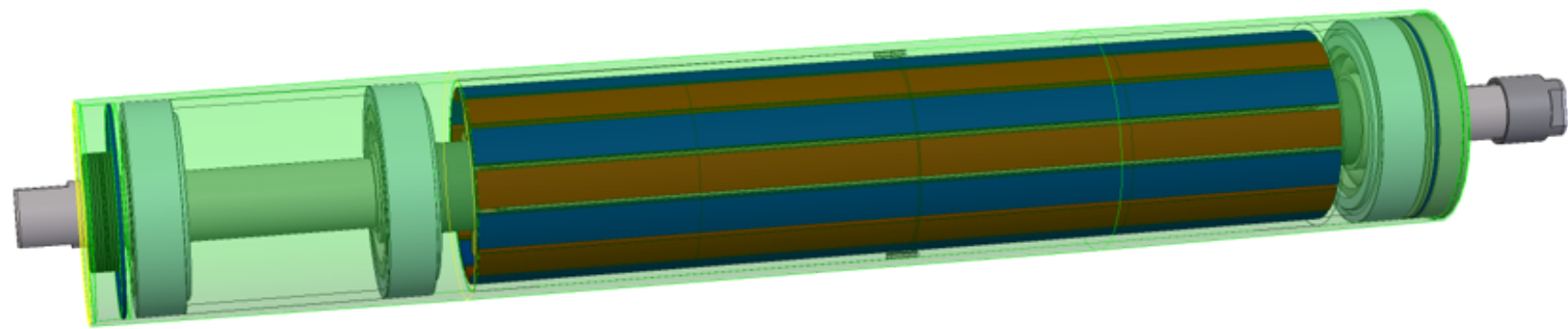

+Watts = +Torque

Advantages over traditional solutions

To compensate for the lower torque, inrunner motors are often equipped with transmissions or gearboxes.

Adding these mechanics lead to even higher build volume, mechanical losses, and cost.

Traditional solutions require more maintenance, energy consumption, increase risk of contamination (oil / grease), and have lower accuracy.

Direct-Drive Technology allows you to build with less moving parts, reducing maintenance and overall build volume.

Space Saving / Maintenance Free

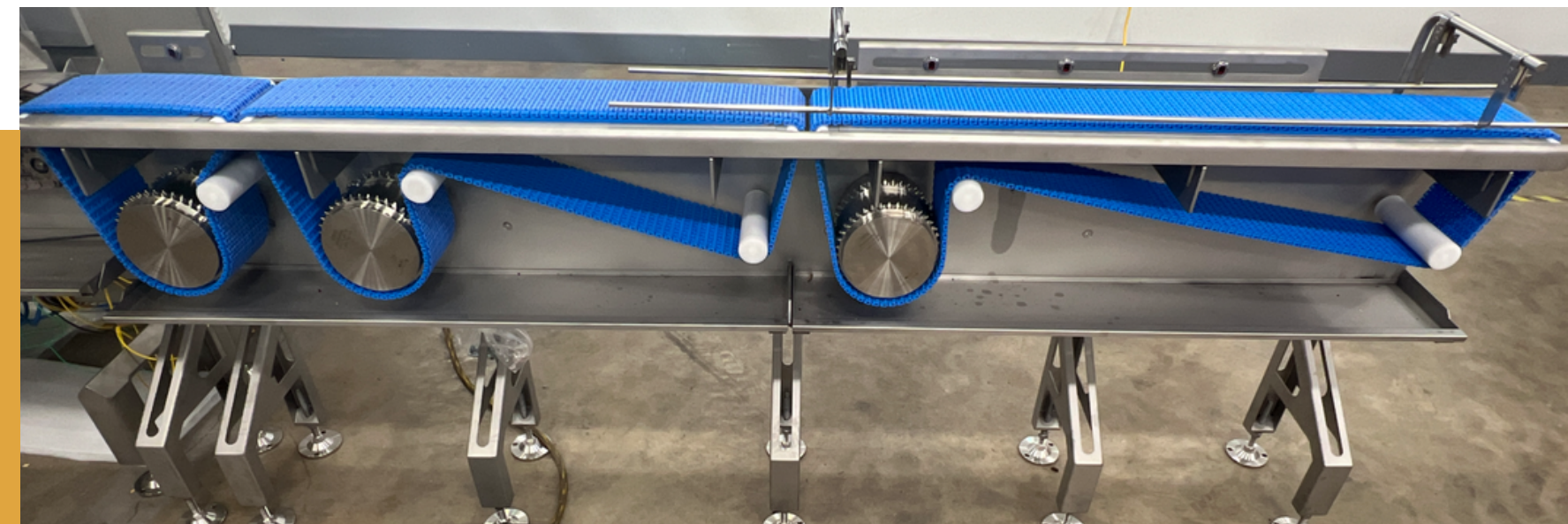
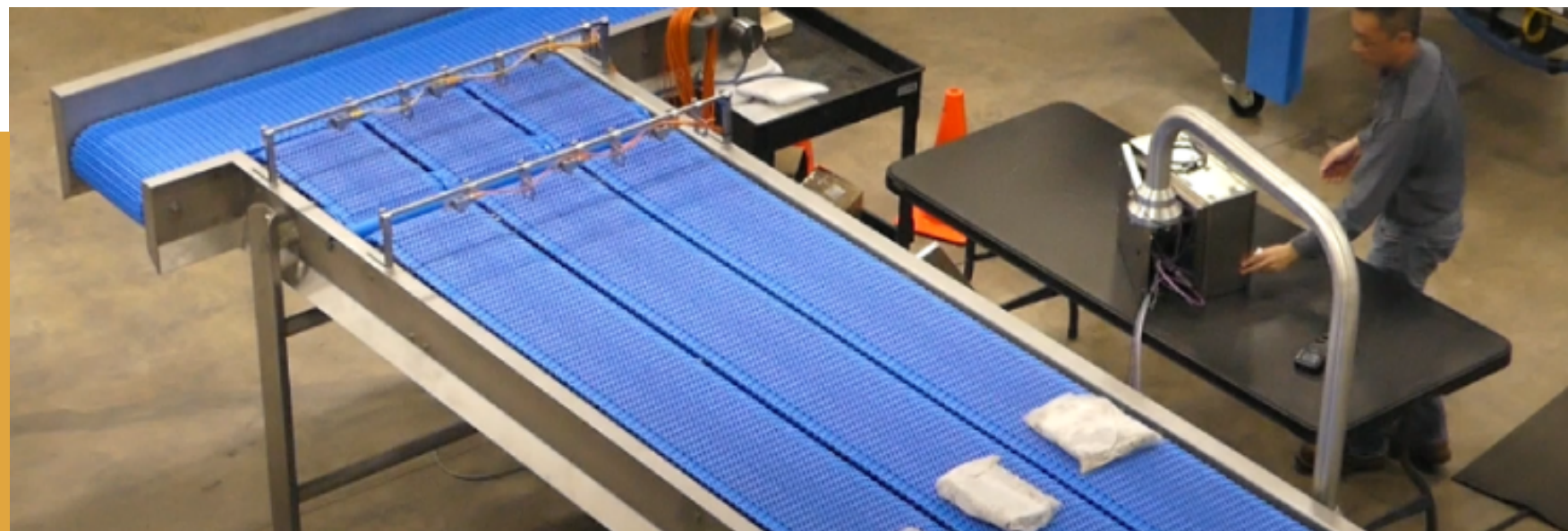

Mag-Drive Products

Powered Hub

Mounted on one side, balcony / cantilevered design.

Powered Pulley

Dual end mount for wider and / or higher torque applications.

Powered Assembly

Superstructure mounted array of single pulley or hub drives.

Powered Multi-Drive

Independently controlled outer faces on the same supporting axis.

Powered Shaft

Active or stationary shell with fixed or hollow shaft.

*This configuration includes 54 Powered Hubs
in an independently driven array



Sprocket / Shell Types

Cut Shell

Machined shell to suit your IP69k application requirements.

Square Drive

Four flats design for use with various sprocket types.

- Set screw sprockets
- IP69k Laser welded sprockets

Fully Sealed / Stainless Steel Design

Mag-Drive products are designed for washdown hygienic applications.

Cut Shell Example



Servo-Like Motion

One Motion Direct-Drive Technology allows for precise motion applications up to 1/16in (0.0625mm) without the need for an encoder or servo drive.

Calculating distance over time allows precise control for complex motion applications such as merging, collation, feeding, indexing & more.

Using any VFD with Permanent Magnet Mode settings, PLC, and Optics you can achieve synchronous, open loop motion.

Our low-profile cantilever design solutions offer space savings and easy maintenance for hygienic automation applications.

Complex Timing and Precision



Programming

Direct-Drive operates using standard VFD devices with permanent magnet mode.

PLC programming is slightly different, due to the open loop nature of our technology.

Speed over time calculations dictate motion for precision product placement.

Virtual axis programming – position in program commands real world position & timing.

We provide application framework programming for smart-belt, merging, grouping & infeed systems.

Training and support services for new programming applications are available from our in-house support team.

No Servo Drive or Encoder Needed

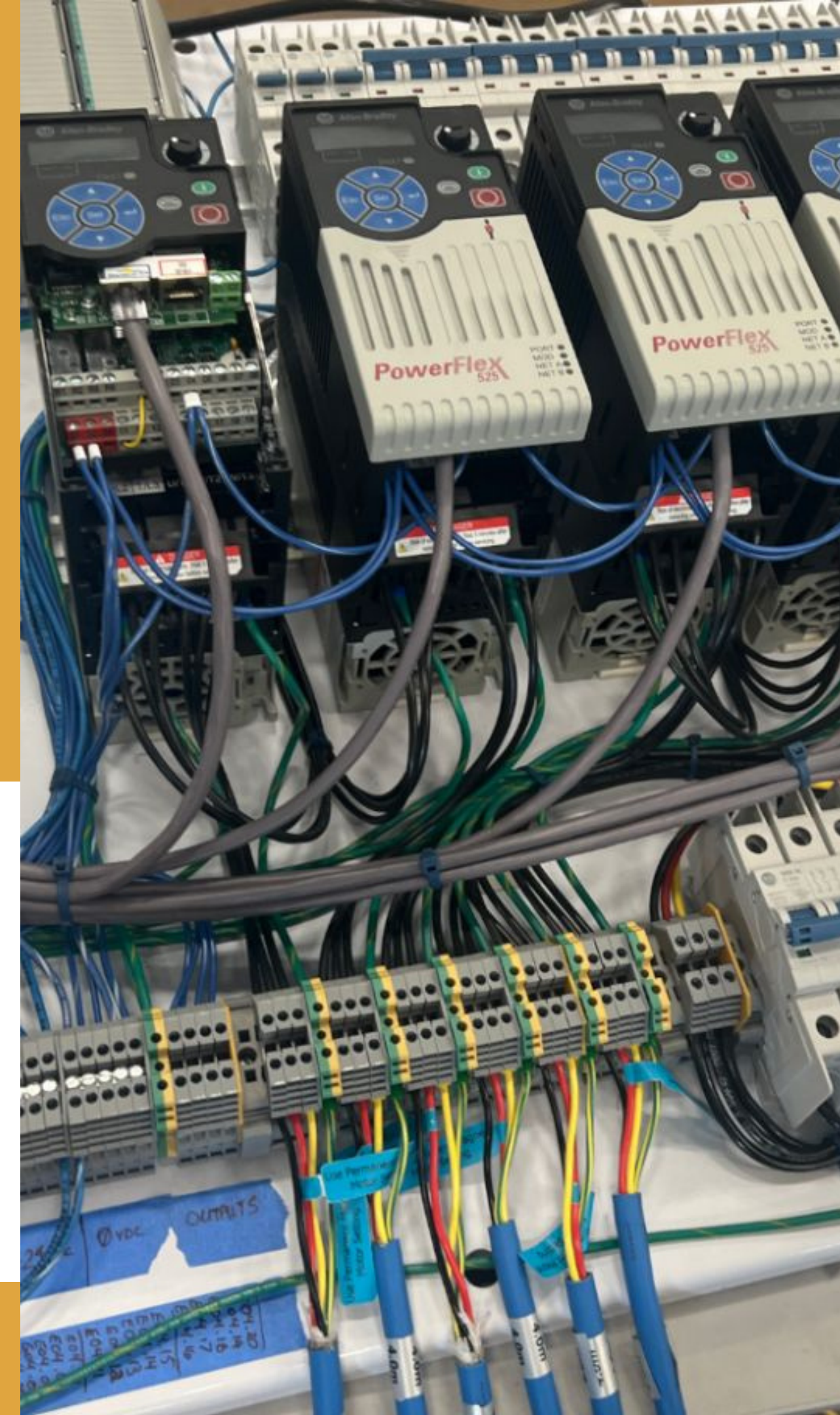

Monitoring / Direct Feedback

Our technology also provides direct feedback using standard output readings from a VFD.

This allows you to detect issues with your machines in real time by monitoring for increases in amperage draw.

This load sensitive monitoring capability is possible due to the direct nature of the motion. Increased amperage draw is a result of resistance in the machine.

Mag-Drive is compatible with any permanent magnet mode capable VFD.

Real-Time System Health Monitoring

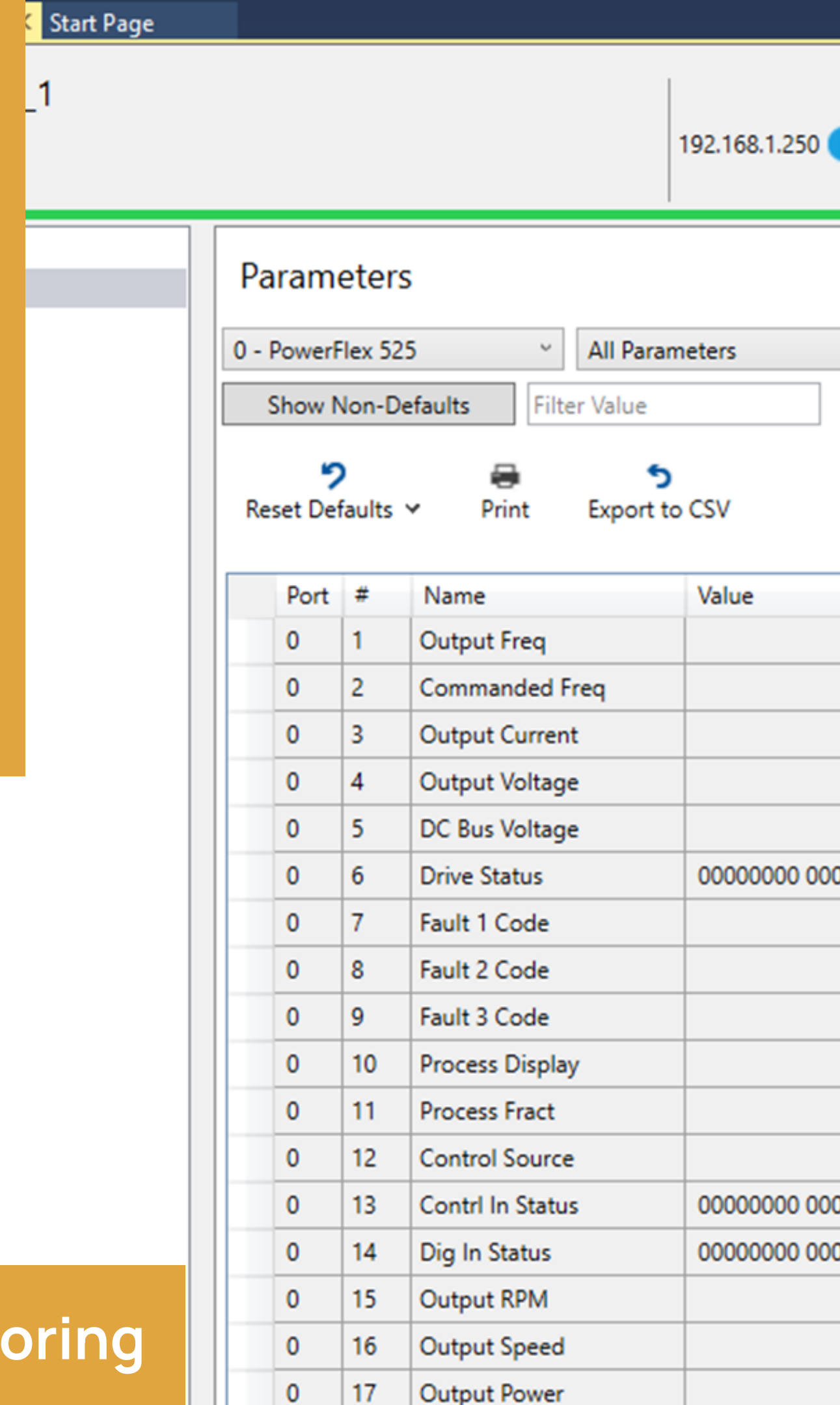

The screenshot shows a web-based interface for monitoring a VFD. At the top, it says 'Start Page' and '192.168.1.250'. Below that, there's a 'Parameters' section with a dropdown menu set to '0 - PowerFlex 525' and a button for 'All Parameters'. There are also buttons for 'Show Non-Defaults' and a 'Filter Value' input field. Below these are icons for 'Reset Defaults', 'Print', and 'Export to CSV'. The main part of the interface is a table with columns for 'Port #', 'Name', and 'Value'. The table lists various parameters such as Output Freq, Commanded Freq, Output Current, Output Voltage, DC Bus Voltage, Drive Status, Fault codes, Process Display, Process Fract, Control Source, Control In Status, Dig In Status, Output RPM, Output Speed, and Output Power.

Port #	Name	Value
0 1	Output Freq	
0 2	Commanded Freq	
0 3	Output Current	
0 4	Output Voltage	
0 5	DC Bus Voltage	
0 6	Drive Status	00000000 000
0 7	Fault 1 Code	
0 8	Fault 2 Code	
0 9	Fault 3 Code	
0 10	Process Display	
0 11	Process Fract	
0 12	Control Source	
0 13	Contrl In Status	00000000 000
0 14	Dig In Status	00000000 000
0 15	Output RPM	
0 16	Output Speed	
0 17	Output Power	



Certified Technician Program

One Motion offers a 3-day hands-on certification program.

Topics include:

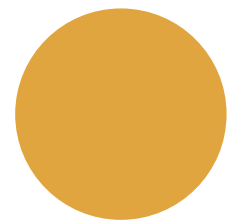

Technology Overview

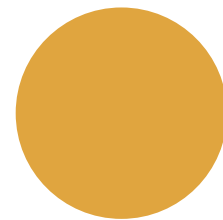

Troubleshooting / Diagnostics

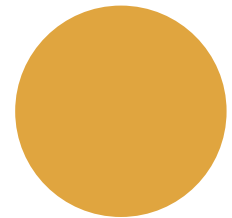

Product Lines / Capabilities

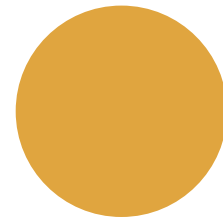

Communication / Reporting

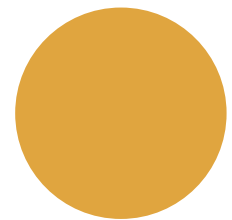

Installation / Configuration

This course will provide hands-on experience working with direct drive technology, allowing you to understand and utilize all the features and benefits of One Motion Technology.



Questions

For information, product literature or general requests.

Contact:

om.orders@actionpaq.com

(479) 358-1173



onemotion.tech



2120 Town W Dr. Rogers, AR. 72756

Scan QR for resources and literature.



ONE MOTION

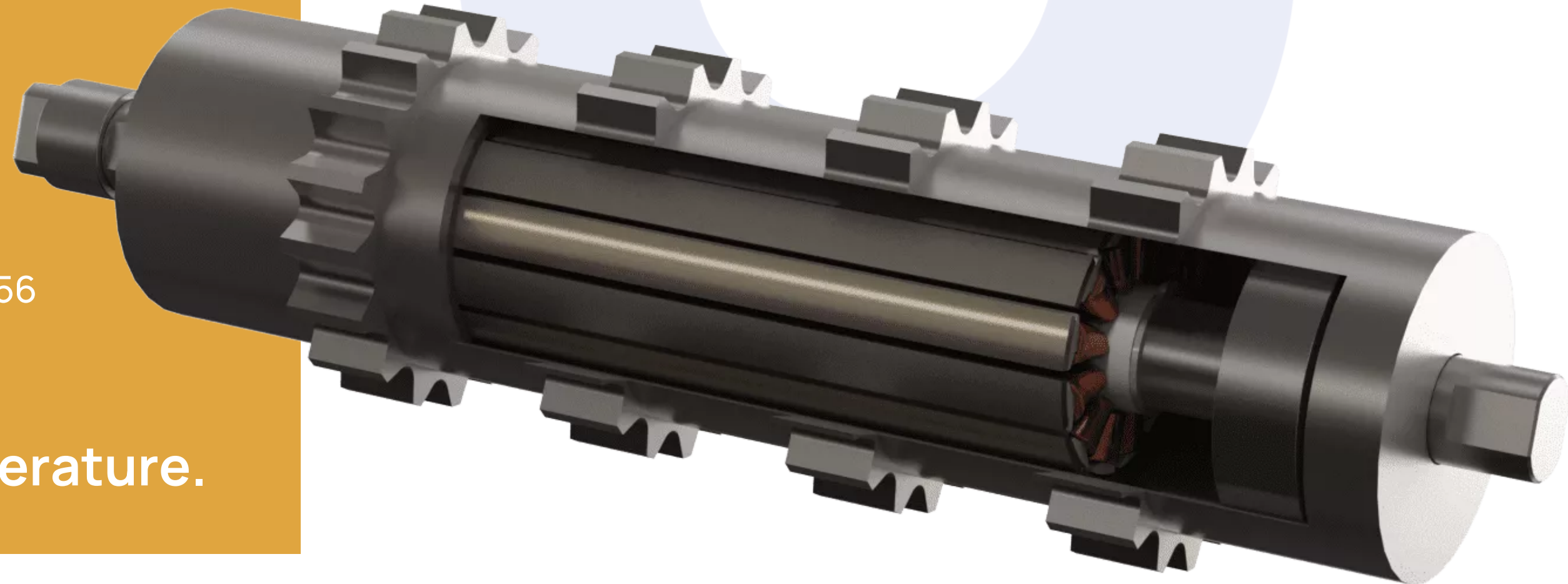



Application Videos



Resources & Support